

# UL and AF Series Motorized Control Valves

Stainless-steel threaded motorized control valves of UL330/350 and AF550/572 series apply to HVAC and building automation systems. Once the motorized control valves receive signals transmitted by computers or other devices, they can then adjust temperature, pressure and control system parameters such as flow rate and liquid level. The valves are mainly used to convey mediums such as cold water, hot water, and ethylene glycol solution.



## Product Features

- **Adopt the AC synchronous hysteresis clutch motor.** When the limited position is reached, the hysteresis clutch disengages the motor's output shaft from the transmission part to protect the motor.
- **High-precision control offers precise actions.**
- **Low power consumption and low noise.**
- **Have the self-adaptive valve travel function.**
- **Multiple signal controls: Increment/floating-point signal, voltage 0 - 10 V, current 4 - 20 mA.**
- **ABS shell and cast-aluminum bracket with the advantages of small size and light weight.**
- **Easy installation and maintenance.**

## Technical Parameters

- Valve Type:** Two-way valve, three-way valve  
**Material:** Shell: stainless steel; disc/stem: stainless steel; sealing: PTFE  
**Working Pressure:** 2.5 Mpa  
**Medium:** Cold water, hot water, vapor, and the aqueous solution of ethylene glycol (concentration within 50%)  
**Medium Temperature:** 0°C ~ 110°C/0°C ~ 150°C with a heat dissipation device  
**Flow Characteristic:** Equal percent curve/equivalent linear  
**Leakage Volume:** Below 0.02% of Kv Value  
**End Type:** BSPT or NPT threaded

## Actuator Parameters

Item	Performance parameters	
	UL series (incremental control model)	AF series (proportional adjustment model)
Power Supply	AC 24 VAC/220 VAC ± 10%, 50 Hz/60 Hz	
Force	500N, 1000N	
Power Consumption	< 5.5VA	
Operating Speed	0.20mm/s (50Hz)	
Control Signal	Increment/floating-point signal	0 ~ 10VDC or 4 ~ 20 mA
Working Temperature	-10°C ~ 50°C (50°F ~ 120°F)	
Humidity	10% ~ 90% RH, no condensation	
Maximum Travel	25 mm	
Actuator Weight	2.4Lbs/1.1 kg ; 2.7Lbs//1.2 kg	
Materials of Main Parts	Fire-retardant ABS plastic shell and die-cast aluminum bracket	
Waterproof Rating	IP54	
Power-Off State	Stay in the current position	
Valve Opening Before Delivery	Middle position	
Manual Function	Have manual operation	
Valve Opening Indication	Have valve opening indication	
Insulation Resistance	Resistance between the power supply terminal and the shell: ≥ 50 MΩ; that between the input terminal and the shell: ≥ 20 MΩ.	
Dielectric Strength	Dielectric strength between the power supply terminal and the shell: 500 V, 50 Hz for AC24V equipment; 1,500 V, 50 Hz for AC220 equipment; that between the input terminal and the shell: 500 V, 50 Hz	

# Dimensions

In		½	¾	1	1 ¼	1 ½	2
mm		15	20	25	32	40	50
L		85	85	90	105	120	140
H	Two-way valve	81	81	85	95	111	123
	Three-way valve	100	100	106	113	131	156
H1	Two-way valve	41	41	39	43	51	56
	Three-way valve	60	60	60	61	70.5	88.5
H2	Two-way valve/three-way valve	40	40	46	52	60	67
H3	Two-way valve/three-way valve	246	246	252	258	266	273

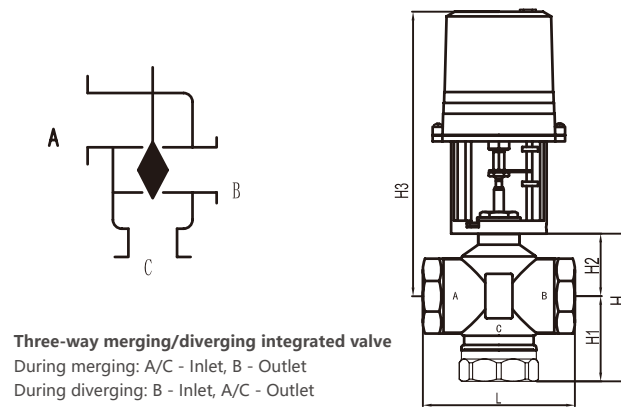
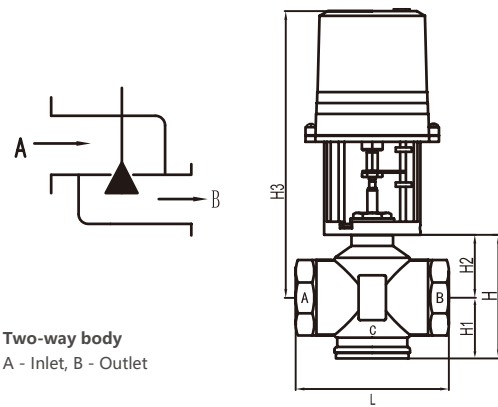

**Note:** Please note that the flow direction of the medium in pipelines is the same as the direction of the valve body's arrow during design and installation.

# Kv (Flow Rate Value), Travel, and Close-Off Differential Pressure

Dimension (In)	Kv value (m³/h)	Travel (mm)	Closed-off differential pressure (MPa) two-way/three-way	
			500N	1000N
½	3	13	0.35	0.70
¾	5	13	0.35	0.70
1	8	13	0.30	0.65
1¼	13	13	0.23	0.60
1½	21	19	0.19	0.47
2	35	19	0.15	0.30

**Note:** The closed-off differential pressure listed in this table refers to the calibration value when the medium is water at 25°C.

# Electrical Wiring Diagrams

Applicable to AC 24 V incremental control models

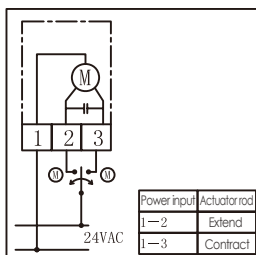

Applicable to AC 24 V analog control models

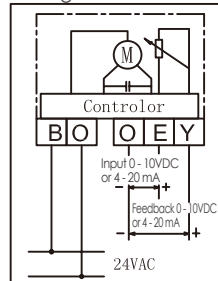

Applicable to AC 220 V incremental control models

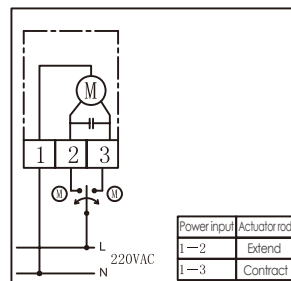

Applicable to AC 220 V analog control models

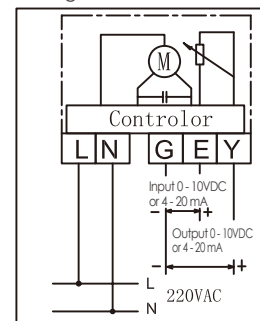

Applicable to all actuator models with passive contacts

